

Standard Solar PV Solutions

Updated: 2 April 2024



Solar PV Solutions

Our prices include:

- **Certificate of Compliance COC**
- **PrEng sign-off and SSEG registration with City of Cape Town**

	Option 1	Option 2	Option 3
Phase	Single-phase	Single-phase	Single-phase
Inverter	1 x Deye Hybrid Inverter Single-Phase 5kW	1 x FoxESS Hybrid inverter Single-Phase 10.5kW (Limited to 8kW by batteries)	1 x Deye Hybrid Inverter Single-Phase 8kW
Battery	1 x Li-Ion Battery 5kWh Total 5kWh	3x FoxESS 2.7kWh HV Li-Ion Battery Total 8kWh (battery QTY determines inverter output power)	1 x Li-Ion Battery 10kWh Total 10kWh
Excluded from Estimate	Additional load-splitting if necessary	Additional load-splitting if necessary	Additional load-splitting if necessary
PV Array Size	3.03kWp 6x 505W	6.66kWp 12x 555W	6.66 kWp 12x 555W
Est. Average Monthly PV Production	~365 kWh	~800 kWh	~800 kWh
Total System Cost Incl. VAT	<i>From R107 000</i>	<i>From R164 000</i>	<i>From R169 000</i>

	Option 4
Phase	Three-phase
Inverter	1 x Deye Hybrid Inverter Three-Phase 12kW (Limited to 10kW by batteries)
Battery	2 x Li-Ion Battery 5kWh Total 10kWh
Excluded from Cost Estimate	Additional load-splitting if necessary
PV Array Size	8.9kWp 16 x 555W
Est. Average Monthly Production	~1090kWh
Total System Cost Incl. VAT	From R216 000

Notes

- **Included: Electrical CoC, PrEng sign-off and SSEG Registration with the City of Cape Town.**
- PV generation calculations based on a North facing 35 degrees roof in the Cape Town area.
- Mounting brackets for corrugated roofing are used for costing.
- Each option can be tailored to the client's requirements, [get in touch with us.](#)

About the solutions

- Deye and FoxESS hybrid inverters provide backup power to your Essential loads with PV and battery priority, and when there is excess PV energy available and the battery is fully charged, power will also be sent to non-Essential loads, further lowering your electricity bill.

Single Phase schematic

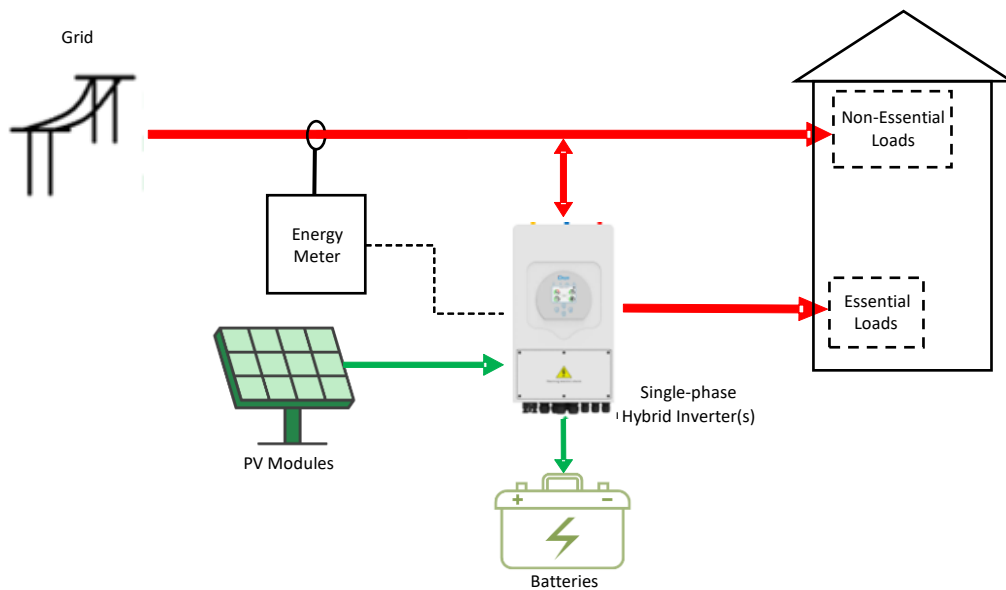

3-phase Schematic

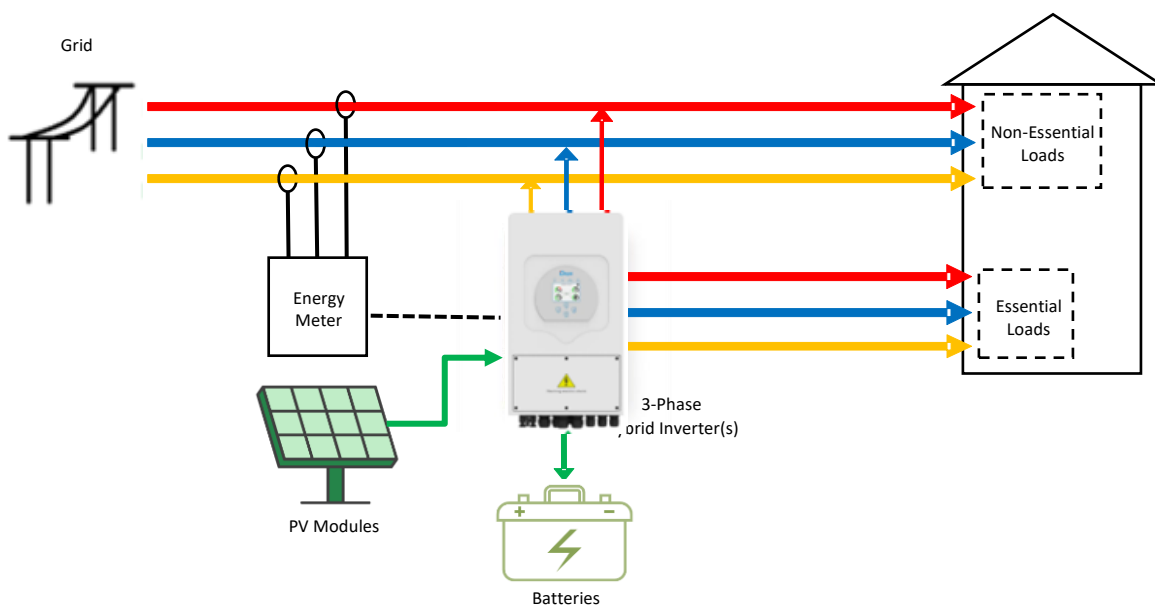

Important For You To Know

- The AWPpower engineering team will provide free tech support (remotely) for one year after installation to assist in optimising the solar system. Thereafter a maintenance and service charge will be applied.
- Estimates are based on the installation of inverter and batteries within 5m of the DB.
- Any additional materials and labour charged by municipality are not included in this proposal.
- Following acceptance of the initial cost estimate, the detailed engineering design may result in changes in configuration and quantities.
- Electrical Labour and materials are estimates and will be confirmed by a final site inspection before installation. Please note changes to existing DB and electrical consumables are not included unless otherwise specified.
- AWPpower reserves the right to adjust the proposed pricing if the Rand/USD exchange rate as published by the South African Reserve Bank on date of receipt of payment for goods differing by more than 5% from the exchange rate on date of this proposal.
- The suppliers of the Goods reserve the right to amend prices without notice. Prices quoted in this document can therefore only be confirmed on receipt of 50% deposit payment.
- **This response is valid for 7 days after the date of preparation and is subject to revalidation thereafter.**
- Balancing of 3-phase supply. It is assumed that the phases are balanced.
- Primary equipment is supplied with the following manufacturer warranties (at the time of this document):
 - Deye inverter: 5 years
 - FoxESS inverter: 10 years
 - Solar PV Modules: 12 years
 - Revov battery: 10 years (or 6000 cycles)
 - FoxESS battery: 10 years (or 6000 cycles)

About AWPpower

Established in 2015, AWPpower is a distinguished provider of solar energy solutions, placing a strong emphasis on engineering services. The company was founded by a collective of industrial, mechanical, and mechatronics engineers driven by their passion for the renewable energy sector and their talent for crafting top-notch systems.

AWPpower provides **Renewable Energy Solutions for Commercial & Residential Buildings in Cape Town and surrounding areas.**

Our unwavering commitment to research and development remains at the core of AWPpower's mission, guaranteeing the delivery of energy-efficient solutions of the highest calibre.

AWPpower actively forges strategic partnerships with reputable organisations such as the Centre for Renewable and Sustainable Energy Studies at the University of Stellenbosch.

Our dedication to quality, innovation, and collaboration enables the company to surpass expectations and meet the unique energy requirements of its valued clients.

We are proud to be voted by [MyBroadband as a Top Home Solar provider in South Africa.](#)

Visit our website for more: www.awpower.co.za



This document has been prepared for the nominated recipients(s). No copies of this document or included information may be distributed to third parties without the expressed written permission of AWPpower (Pty) Ltd. Strictly Private and Confidential
© 2024. All rights reserved. E&OE

Email: info@awpower.co.za

Telephone: 0861-111-601